

# 2012 magazine specifications



# REPORT ON BUSINESS

MAGAZINE

\*STANDARD FORMATS APPLY TO REPORT ON BUSINESS MAGAZINE AND CANADIAN UNIVERSITY REPORT

\*ADVANCED FORMATS APPLY TO REPORT ON BUSINESS MAGAZINE ONLY

SPECIFICATIONS SUBJECT TO CHANGE VISIT OUR WEBSITE FOR UPDATES

FOR FURTHER ADVERTISING INFORMATION PLEASE VISIT GLOBELINK.CA

UPDATED JANUARY 2012

## advertising formats standard



**FULL PAGE**

LIVE: 7" w x 10" d  
TRIM: 7 7/8" w x 10 3/4" d  
BLEED: 8 1/8" w x 11" d



**INSIDE BACK COVER**

LIVE: 7" w x 10" d  
TRIM: 7 7/8" w x 10 3/4" d  
BLEED: 8 1/8" w x 11" d

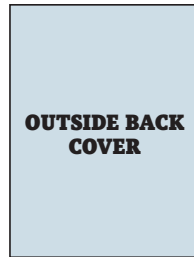

**OUTSIDE BACK COVER**

LIVE: 7" w x 10" d  
TRIM: 7 7/8" w x 10 3/4" d  
BLEED: 8 1/8" w x 11" d

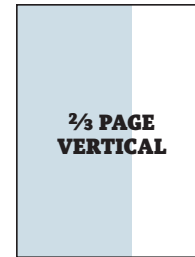

**2/3 PAGE VERTICAL**

LIVE: 4 3/8" w x 10" d  
TRIM: 4 5/8" w x 10 3/4" d  
BLEED: 4 7/8" w x 11" d

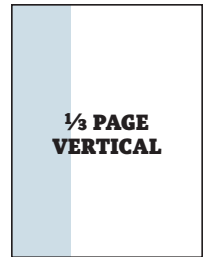

**1/3 PAGE VERTICAL**

LIVE: 2" w x 10" d  
TRIM: 2 1/4" w x 10 3/4" d  
BLEED: 2 1/2" w x 11" d

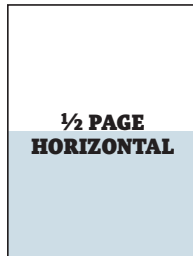

**1/2 PAGE HORIZONTAL**

LIVE: 7" w x 4 15/16" d  
TRIM: 7 7/8" w x 5 3/8" d  
BLEED: 8 1/8" w x 5 5/8" d

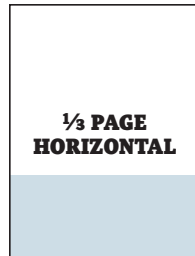

**1/3 PAGE HORIZONTAL**

LIVE: 7" w x 3 1/8" d  
TRIM: 7 7/8" w x 3 3/8" d  
BLEED: 8 1/8" w x 3 5/8" d

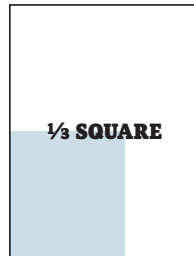

**1/3 SQUARE**

LIVE: 4 3/8" w x 4 15/16" d  
TRIM: 4 5/8" w x 5 3/8" d  
BLEED: 4 7/8" w x 5 5/8" d

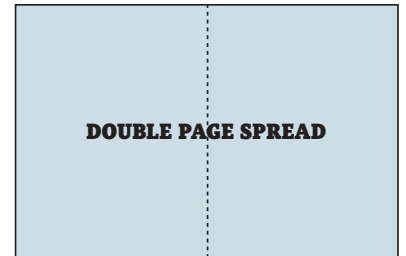

**DOUBLE PAGE SPREAD**

LIVE: 14" w x 10" d  
TRIM: 15 3/4" w x 10 3/4" d  
BLEED: 16 1/4" w x 11" d

\*MUST BUILD AS TWO SEPERATE PAGES

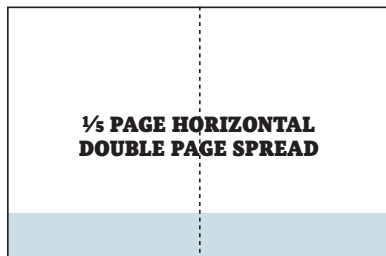

**1/5 PAGE HORIZONTAL DOUBLE PAGE SPREAD**

LIVE: 14" w x 1 5/8" d  
TRIM: 15 3/4" w x 2" d  
BLEED: 16 1/4" w x 2 1/4" d

\*MUST BUILD AS TWO SEPERATE PAGES

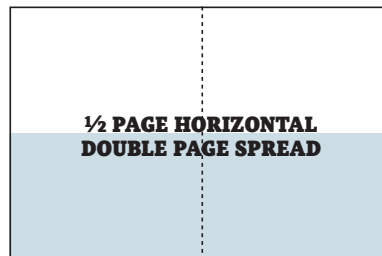

**1/2 PAGE HORIZONTAL DOUBLE PAGE SPREAD**

LIVE: 14" w x 4 15/16" d  
TRIM: 15 3/4" w x 5 3/8" d  
BLEED: 16 1/4" w x 5 5/8" d

\*MUST BUILD AS TWO SEPERATE PAGES

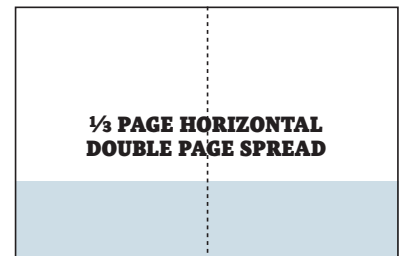

**1/3 PAGE HORIZONTAL DOUBLE PAGE SPREAD**

LIVE: 14" w x 3 1/8" d  
TRIM: 15 3/4" w x 3 3/8" d  
BLEED: 16 1/4" w x 3 5/8" d

\*MUST BUILD AS TWO SEPERATE PAGES

## advanced formats

### 1/3 HORIZONTAL

LIVE: 7" w x 3 1/8" d  
TRIM: 7 7/8" w x 3 3/8" d  
BLEED: 8 1/8" w x 3 5/8" d

### 1/3 VERTICAL

LIVE: 2" w x 10" d  
TRIM: 2 1/4" w x 10 3/4" d  
BLEED: 2 1/2" w x 11" d

### REVERSE L

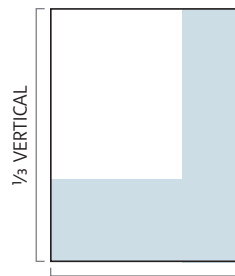

1/3 VERTICAL

1/3 HORIZONTAL

### RACETRACK

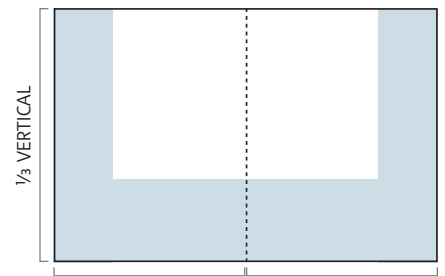

1/3 VERTICAL

1/3 HORIZONTAL

1/3 HORIZONTAL

\*SPECIAL FORMATS APPLY TO REPORT ON BUSINESS MAGAZINE ONLY

advertising formats  
**special**

**GATEFOLD • INSIDE FRONT COVER**

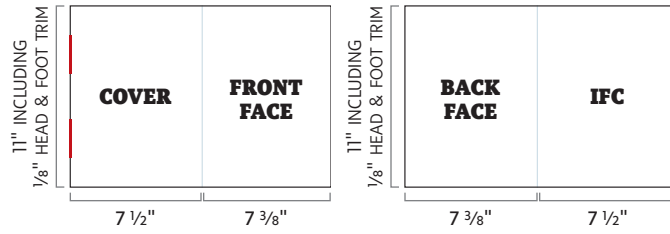

6 PAGES LEFT HAND, IF CENTER TO THE MAGAZINE  
1 x 4 PAGE GATEFOLD IN LOW FOLIO IF BETWEEN 2 SECTIONS

**GATEFOLD • 1/3 COVER**

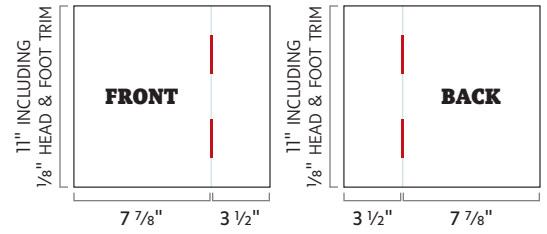

AD WRAPS AROUND COVER

**GATEFOLD • 2/3**

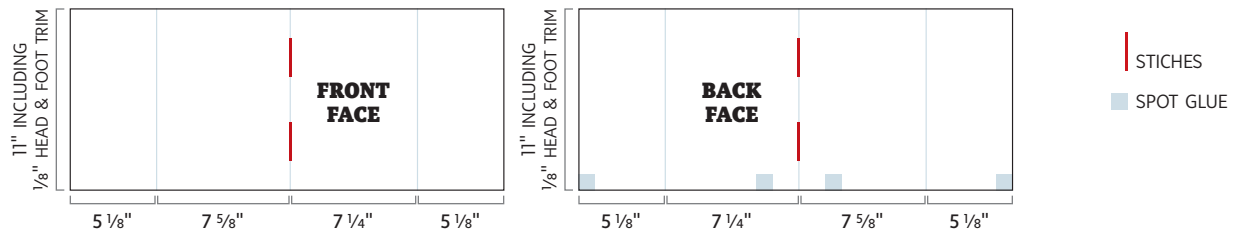

**GATEFOLD • 4 PAGE**

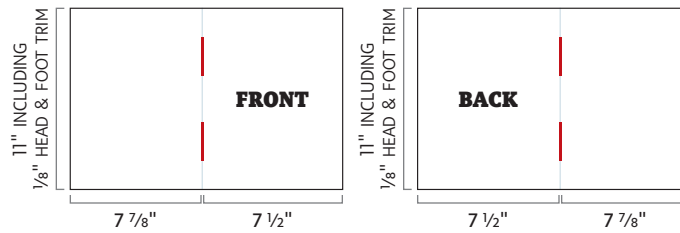

4 PAGES GATEFOLD, IF CENTER TO THE MAGAZINE  
2 x 2 PAGES IF BETWEEN 2 SECTIONS

**GATEFOLD • 1/3 PAGE**

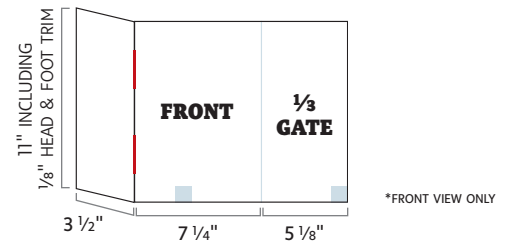

**GATEFOLD • 6 PAGE**

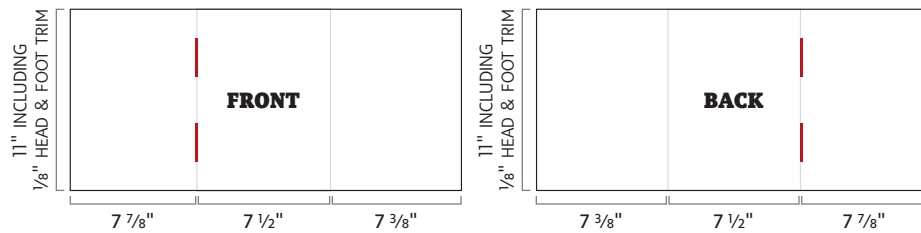

6 PAGES LEFT HAND, IF CENTER TO THE MAGAZINE  
1 x 4 PAGE GATEFOLD IN LOW FOLIO IF BETWEEN 2 SECTIONS

**GATEFOLD • 8 PAGE**

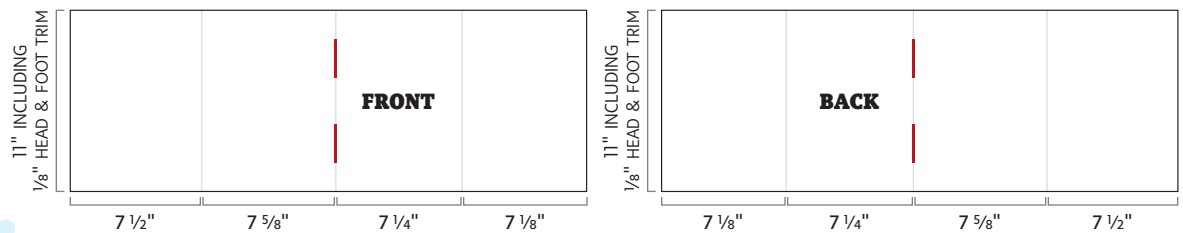

8 PAGES LEFT HAND, IF CENTER TO THE MAGAZINE  
2 x 4 PAGE GATEFOLD IF BETWEEN 2 SECTIONS



advertising formats  
**creative executions**



**REVERSE L**



**RACETRACK**



**DOUBLE 1/3 BANNER**



**DOUBLE 1/3 BANNER**



**CANDLESTICKS**



**MASTHEAD BOOKENDS**



**MASTHEAD DPS**



**CONSECUTIVE 1/3 BANNERS**



**CONSECUTIVE 1/3 VERTICAL**



**CONSECUTIVE BUILD**



specifications & general  
requirements

## General

- DPS ads must be set up as single pages
- All disks (CD or DVD) must be supplied with a digital halftone proof (eg. Polaproof, Kodak Approval)
- Laser proofs and colour keys are not acceptable proofs
- **Electronically sent material not accepted**
- **All display ads must be sent to: Report on Business magazine  
444 Front Street West  
Toronto ON M5V 2S9**

## General Requirements for Mac

- QuarkXpress 7.0 and up to InDesign CS5 Files
- All high-resolution files in CMYK (minimum 300 dpi)
- All TIFFS and EPS files must be placed in your document
- Adobe Illustrator files must be saved with a preview and all placed art or images must be included
- All screen and printer fonts used in the document (plus all EPS files) must be supplied
- All colours must be defined as CMYK with separation turned on in the edit colours dialog box
- Ads with drop shadows should be layered in offset text boxes
- Crop marks should be offset
- Include a printout of the directory list of all files, fonts, EPS files, etc.

## General Requirements for PDF Files

- Optimized PDF\_x1a with thumbnail preview
- Output resolution set to 2400 dpi
- No compression or resampling
- Embed all fonts
- Crop marks should be offset
- All embedded art or images should be high resolution in CMYK (minimum 300 dpi)
- No colour conversion and all colours should be defined as CMYK

## Mechanical Specifications

- Web offset printing
- 133 Line Screen
- Saddle Stitched
- \*Double page spreads: Any headline text crossing the gutter must stay clear of the fold by 1/4" on both pages (total 1/2" between words or characters)

## Positioning

- 15% on earned space rates
- Covers are non-cancelable

## For More Information

If you require any further information please contact your Globe and Mail advertising representative or:

Liz Massicotte at 416-585-5484 or by email at [lmassicotte@globeandmail.com](mailto:lmassicotte@globeandmail.com) or visit [globelink.ca/magazines](http://globelink.ca/magazines)



advertising formats  
**inserts**

**SCENT STRIP**

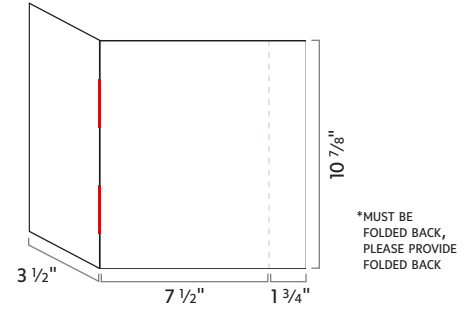
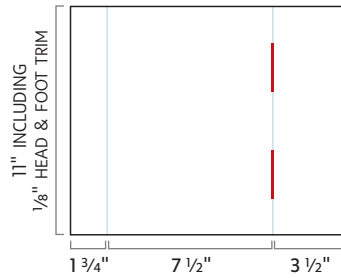
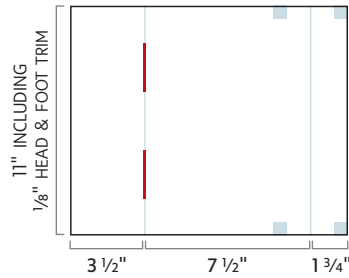

**BUSINESS REPLY CARD**

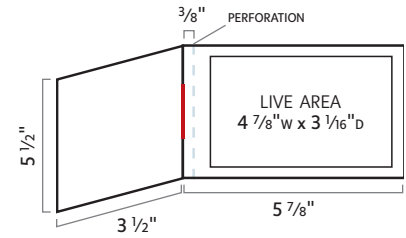
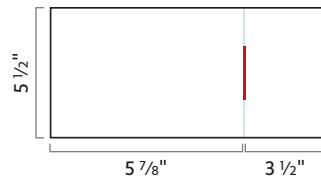
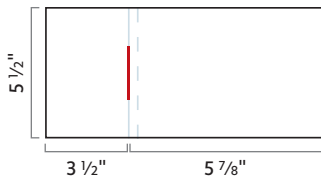

**SINGLE-PAGE STITCHED-IN INSERT**

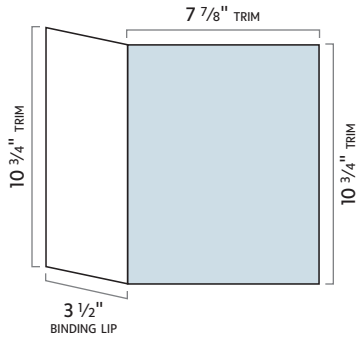

**MULTI-PAGE STITCHED-IN INSERT**

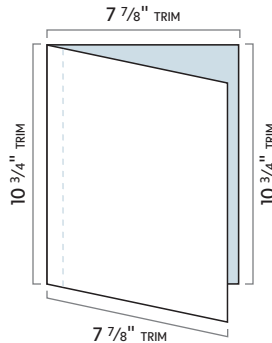

**TIP-IN INSERT**

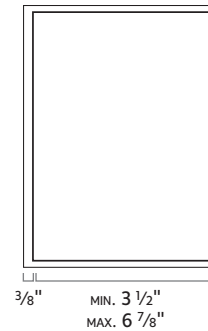

STICHES  
SPOT GLUE

**LOW FOLIO** FRONT TO CENTER: 1/8" BLEED  
**HIGH FOLIO** CENTER TO BACK: 1/8" BLEED + 3/8" LIP  
\*MULTI-PAGE: MUST BE PRESTITCHED OR UNTRIMMED FORM

**Packaging and receiving criteria for inserts supplied by the client**

- Inserts can be supplied either directly by the client or by the client's supplier
- A minimum of 2% must be added to the quantity for spoilage
- Inserts must be delivered in good quality, uniform boxes, weighing a maximum of 35lbs, in a manner that keeps them from moving around
- Boxes must be delivered on good quality standard size skids
- 25 samples of each insert must be supplied to Report on Business magazine to:

Isabelle Oandasan  
444 Front Street West  
Toronto ON M5V 2S9

**The following information must appear on the delivery slip**

- Client's name
- Item or description of the content
- Name of the magazine to be inserted into
- Issue date
- Quantity per box and total quantity
- **The information above must appear on each box**

**Insert Shipping Address**

Transcontinental Printing, Imprimerie Interweb Inc.  
1603 Montarville Blvd., Shipping & Receiving, Door 10  
Boucherville QC J4B 5Y2  
tel: 450-655-2801 fax: 450-655-0765  
Monday to Friday 8AM to 5PM excluding holidays



REPORT ON  
**SMALL BUSINESS**  
 THE GLOBE AND MAIL

<http://www.globelink.ca/magazines>

SPECIFICATIONS SUBJECT TO CHANGE VISIT OUR WEBSITE FOR UPDATES

FOR FURTHER ADVERTISING INFORMATION PLEASE VISIT [GLOBELINK.CA](http://GLOBELINK.CA)

UPDATED JANUARY 2012

\*TABLOID FORMATS APPLY TO REPORT ON SMALL BUSINESS MAGAZINE ONLY

advertising formats  
**tabloid**



**FULL PAGE**  
 LIVE: 236mm w x 251mm d  
 9.29"w x 9.88"d



**INSIDE BACK COVER**  
 LIVE: 236mm w x 251mm d  
 9.29"w x 9.88"d

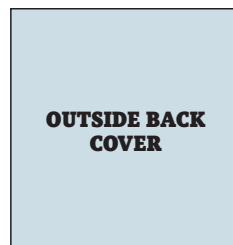

**OUTSIDE BACK COVER**  
 LIVE: 236mm w x 251mm d  
 9.29"w x 9.88"d

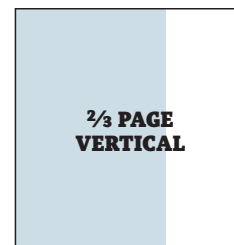

**2/3 PAGE VERTICAL**  
 LIVE: 156mm w x 251mm d  
 6.14"w x 9.88"d

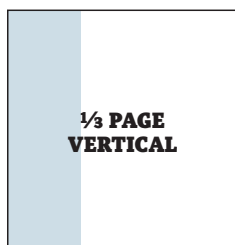

**1/3 PAGE VERTICAL**  
 LIVE: 76mm w x 251mm d  
 2.99"w x 9.88"d

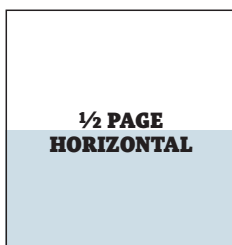

**1/2 PAGE HORIZONTAL**  
 LIVE: 236mm w x 125mm d  
 9.29"w x 4.92"d

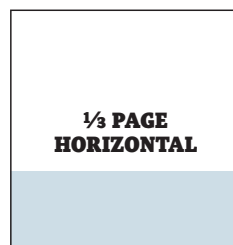

**1/3 PAGE HORIZONTAL**  
 LIVE: 236mm w x 82mm d  
 9.29"w x 3.22"d

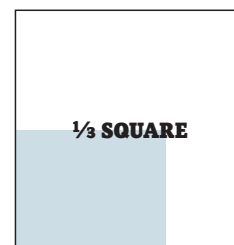

**1/3 SQUARE**  
 LIVE: 156mm w x 125mm d  
 6.14"w x 4.92"d

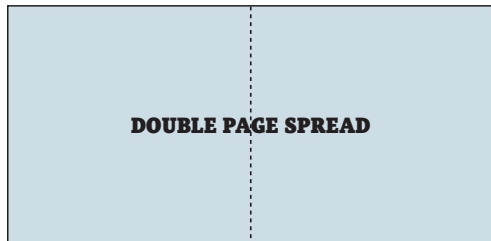

**DOUBLE PAGE SPREAD**  
 LIVE: 498mm w x 251mm d  
 19.57"w x 9.88"d

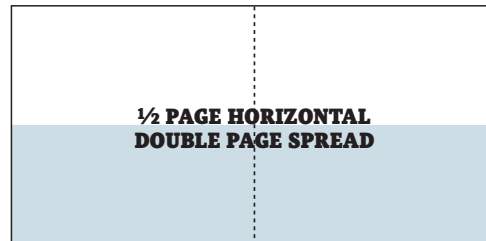

**1/2 PAGE HORIZONTAL DOUBLE PAGE SPREAD**  
 LIVE: 498mm w x 125mm d  
 19.57"w x 4.92"d

DOUBLE PAGE SPREAD RUNS ACROSS GUTTER, ONLY AVAILABLE IN CENTER SPREAD

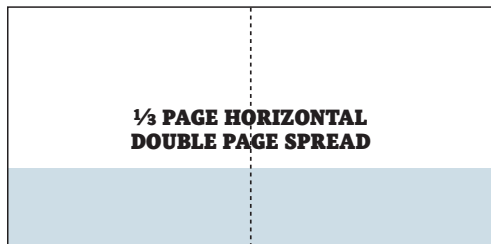

**1/3 PAGE HORIZONTAL DOUBLE PAGE SPREAD**  
 LIVE: 498mm w x 82mm d  
 19.57"w x 3.22"d

DOUBLE PAGE SPREAD RUNS ACROSS GUTTER,  
 ONLY AVAILABLE IN CENTER SPREAD

\*AD SIZES ARE PRINTABLE AREA ONLY, WE CANNOT ACCEPT BLEED ADS



REPORT ON  
**SMALL BUSINESS**  
THE GLOBE AND MAIL

\*REQUIREMENTS FOR REPORT ON SMALL BUSINESS MAGAZINE

<http://www.globelink.ca/magazines>

SPECIFICATIONS SUBJECT TO CHANGE VISIT OUR WEBSITE FOR UPDATES

FOR FURTHER ADVERTISING INFORMATION PLEASE VISIT [GLOBELINK.CA](http://GLOBELINK.CA)

UPDATED JANUARY 2012

specifications & requirements  
**tabloid**

### General

- Ads must be created at 100% final booked size
- Ad material not sent in at final size may be floated within the ad space or scaled to fit
- The given ad size is the final trim size, there is no bleed allowance
- No trapping, chokes or spreads should be used
- DPS ads must be set up as single pages
- **All display ads must be sent to: Report on Business magazine**  
**444 Front Street West**  
**Toronto ON M5V 2S9**

### General Requirements

- Ad material should be created in a page layout (ie. Adobe InDesign or QuarkXPress) or design (ie. Adobe Illustrator) program
- All high-resolution files in CMYK (minimum 266 dpi)
- All TIFFS and EPS files must be placed in your document
- Adobe Illustrator files must be saved with a preview and all placed art or images must be included
- All screen and printer fonts used in the document (plus all EPS files) must be supplied (do not use artificial type styles)
- All colours must be defined as CMYK with separation turned on in the edit colours dialog box
- Maximum total ink coverage: 240%
- Midtone dot gain: 26%
- Minimum line thickness: 0.5pt

### General Requirements for PDF Files

- Optimized PDF\_x1a with thumbnail preview
- Output resolution set to 2400 dpi
- No compression or resampling
- Embed all fonts
- All embedded art or images should be high resolution in CMYK (minimum 266 dpi)
- No colour conversion and all colours should be defined as CMYK

### Mechanical Specifications

- Web offset printing
- 133 Line Screen
- Saddle Stitched
- \*Double page spreads: Any headline text crossing the gutter must stay clear of the fold by 1/4" on both pages (total 1/2" between words or characters)

### Positioning

- 15% on earned space rates
- Covers are non-cancelable

### For More Information

If you require any further information please contact your Globe and Mail advertising representative or:

Liz Massicotte at 416-585-5484 or by email at [lmassicotte@globeandmail.com](mailto:lmassicotte@globeandmail.com) or visit [globelink.ca/magazines](http://globelink.ca/magazines)

